

## Atoll Pool Float

### Assembly | User Guide

One person required for safe assembly

#### Opening Boxes:

DO NOT use a knife to open the packaging as you may damage your pool float. Peel off the tape, then lift & separate the cardboard flaps to open.

Assemble your pool float by following the instructions below.

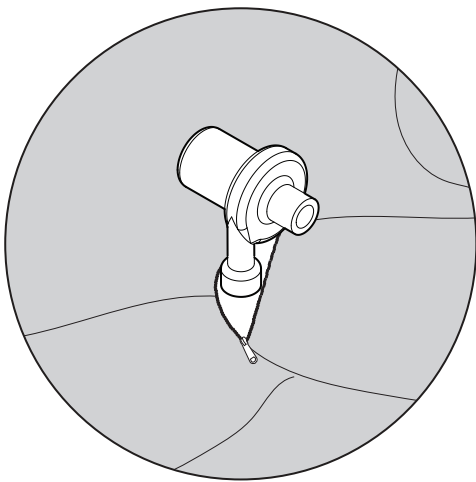

#### WARNING

Please ensure you read the **Air Pump User Guide | Safety Manual** (provided with the product), before operating the air pump. To download the online manual please visit: [kingliving.com](http://kingliving.com)

#### Operating Air Pump Safely:

- Connect air pump directly to electrical supply
- Ensure the valves are not obstructed
- Do not use or store air pump in wet conditions
- Do not use air pump when pool float is wet
- Never put hands/fingers into the air pump ports
- Protect eyes while operating air pump:
  - never look into air pump ports
  - never point air pump ports towards eyes
- Keep air pump out of reach of children
- Do not leave air pump unattended when in use
- Ensure inflation/deflation zone is clean & dry and ensure that small particles (e.g. sand, or stones etc) can't be sucked into the air pump ports

1

#### Inflation

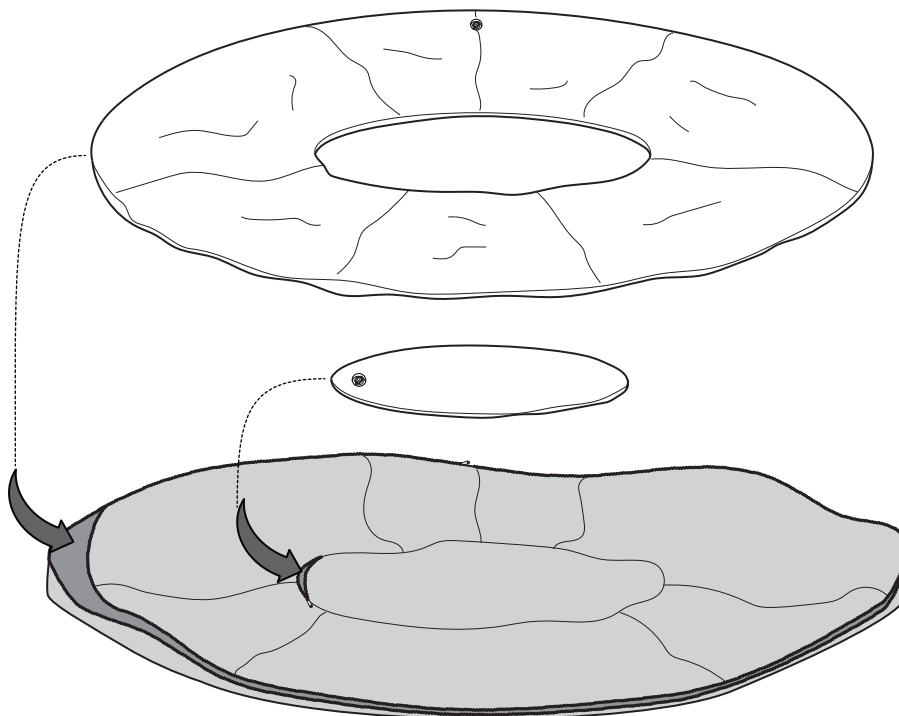

2

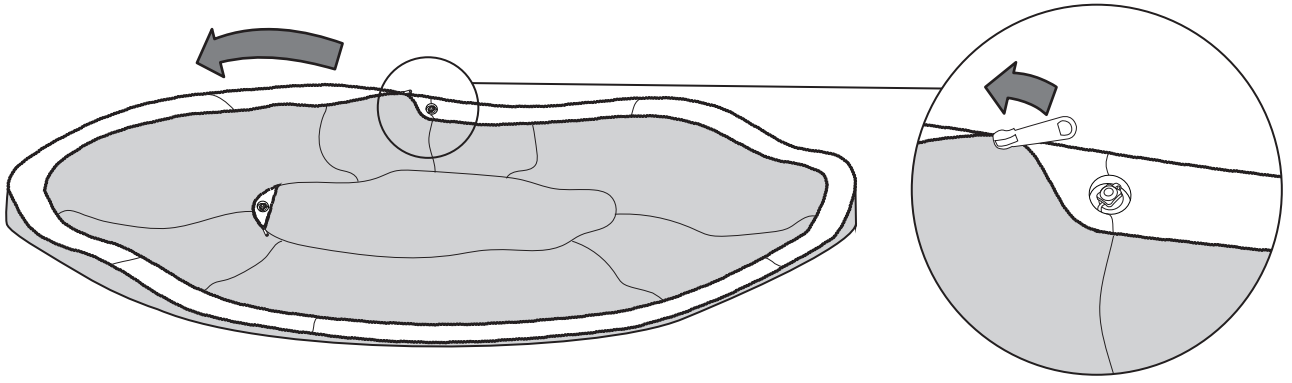

3

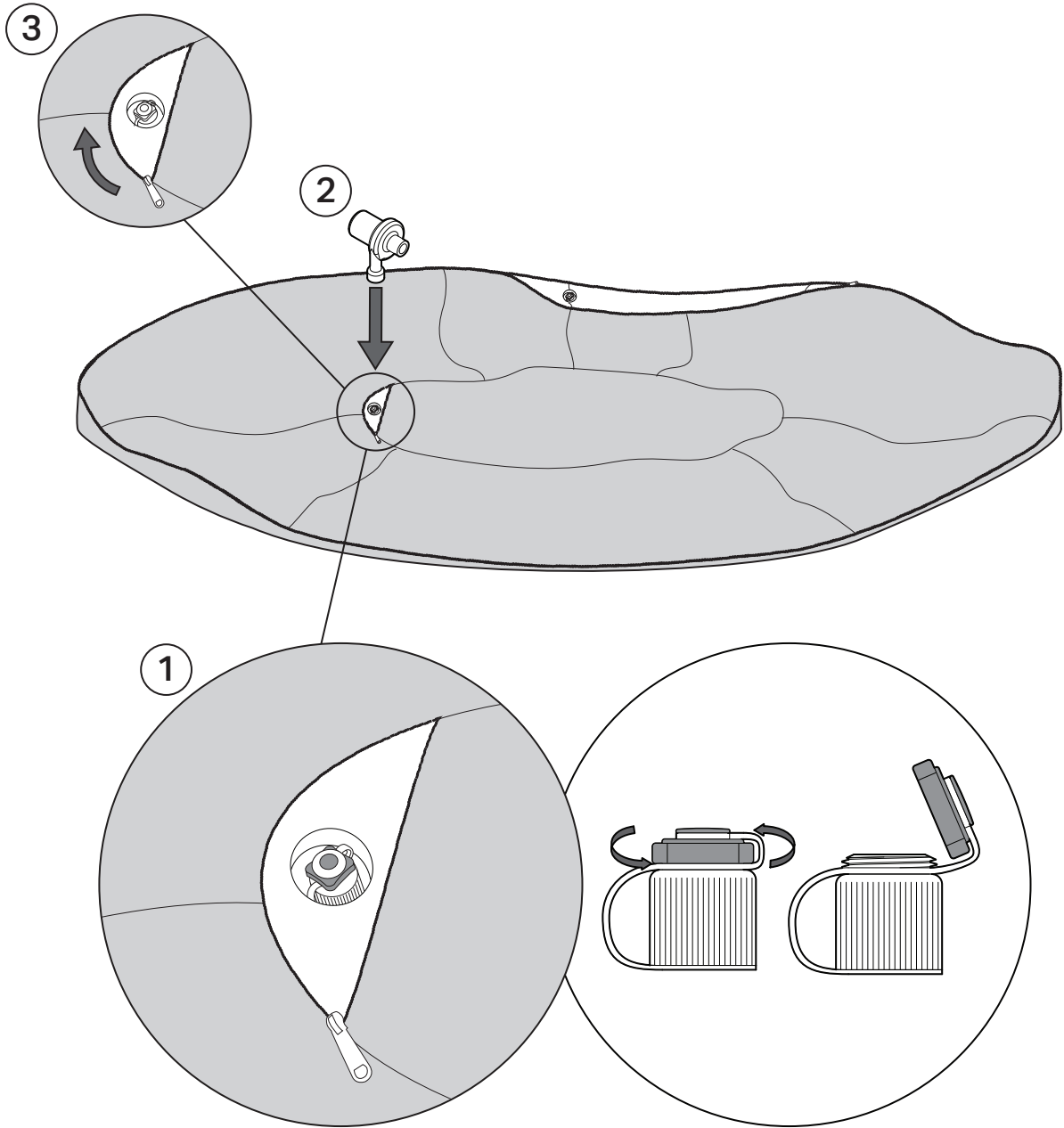

4

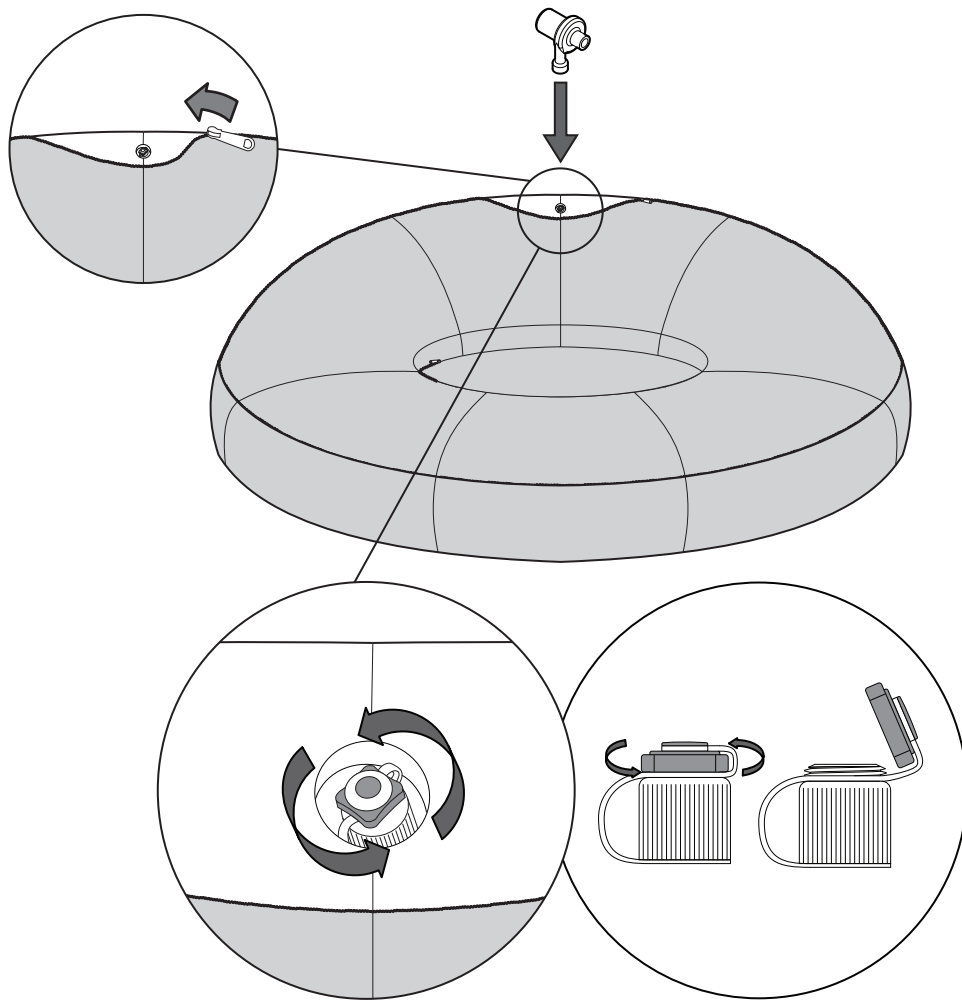

5

Deflation

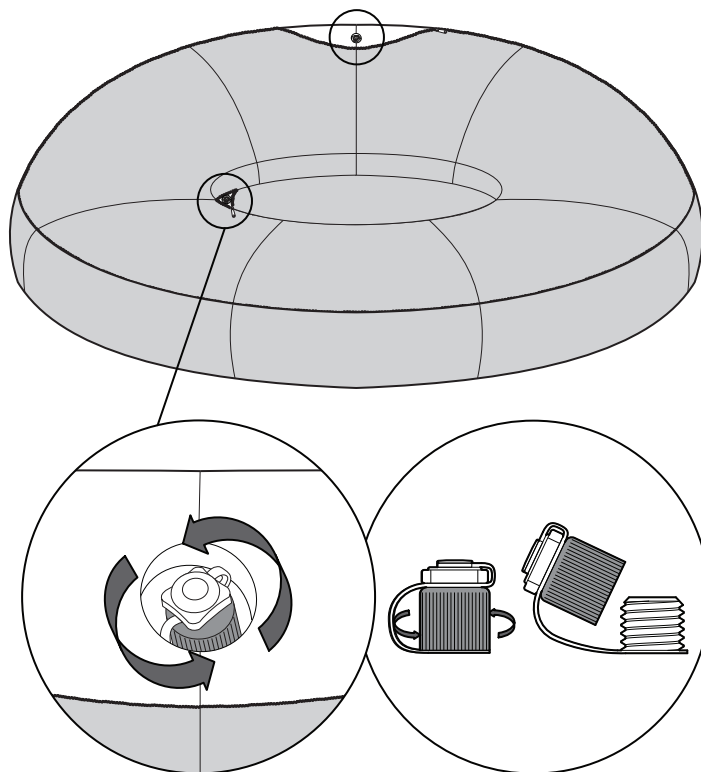

## Pool Float

### Product Warnings | Safety Guide



**Please ensure you read, understand and follow the product warnings and safety guidelines before using your pool float.**

These product warnings and safety guidelines highlight some common risks associated with recreational pool floats, however these product warnings and safety guidelines do not cover all associated risks or dangers.

Caution and general water-safety are advised at all times while using this product.

Not following these guidelines could result in drowning or serious injury.

#### **Product Warnings | Safety Guide:**

- Pool float is for recreational use only
  - for swimmers aged 14+ years
- Pool float is not a life-saving device
  - no protection from drowning
- Do not use in high winds
- Pool float is for use in swimming pools with clean water
  - do not use in rapid/dangerous currents, open water or ocean tides
  - water should be clear of debris and obstructions
- Do not allow jumping/diving onto, or from pool float
- Do not exceed maximum weight: 120kg (264.5lb)
- Distribute load (person/s) evenly
- Do not use if puncture or leak detected
- Do not use under the influence of alcohol or drugs

#### **Maintenance:**

- Check seams and valves regularly for tears and leaks
- Clean the pool float after each use with clean water (e.g. garden hose) and air-dry thoroughly before storage

#### **Repair:**

- Patch the pool float if a tear or leak is detected
- Ensure the pool float is dry before patching
- Cut a section of the repair patch large enough to overlap the damaged area by ~15mm (.75")
- Round-off the edges, place the patch over damaged area and press down firmly
- Place a weight on top to hold patch securely in place
- Do not inflate for one hour after patching
- If patch doesn't hold
  - try silicon or polyurethane-based glue as used for repairing outdoor equipment (e.g. mats, tents, and shoes etc), to secure the patch